



# Protect your Through-The-Wall ATM against gas & solid explosive attacks

**ShockBuster™ TTW prevents explosives from entering the safe.**

One of the key challenges that banks face today is how to ensure their ATMs are safe for their customers and commercial surroundings.

With ATM explosions on the rise in many parts of the world, there are on-going discussions on what is the best way to tackle this very serious problem. We believe in **prevention first**. We make it difficult to get to the cash.

**InfoMAT's ShockBuster solution is:**

**1** Preventative by design

**2** Proven effective against attack

**3** Providing an impressive ROI

**Working hard to ensure your ATM remains secure and protected.**

ShockBuster TTW complements any Intelligent Banknote Neutralisation System (IBNS) on the market today. We embrace a fully integrated approach as an industry best practice.

Cameras, cassette transport, gas-resistant safes and even protective barriers are all excellent solutions to attacks, however, most come in to play once the explosion has already occurred and not one solution solves for both gas and solid explosives.

For more information, visit [infomatservices.com](http://infomatservices.com), or write to: [info@infomatservices.com](mailto:info@infomatservices.com).

**InfoMAT**  
SERVICES

# ATM Physical Security

## ShockBuster™ TTW

Prevent any serious damage from impacting your business, your investments, and lives with one simple ATM add-on.

### HOW IT WORKS

---

- Added shutter sensors used to perform intelligent analysis between tampering (attack) or mechanical malfunctioning
- High grade reinforced steel plate is kept in position to protect objects from being inserted into the safe
- Alarm hub provides immediate notification whether audible, visible, or silent alarms
- Without any delays, cash is presented and safe opening remains sealed
- Electro-mechanically controlled protective door requiring no changes to the ATM's software and/or firmware
- Additional secure plate closing off any entry from ATMs top section

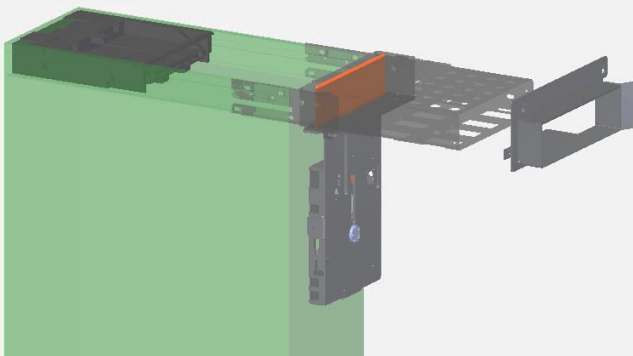

### PREVENTION STARTS NOW

---

ShockBuster TTW

- installed either at the factory or on-site
- compliant to all CE regulations
- does not impact existing maintenance
- multi-vendor enabled
- available for cash recyclers, cash out and cash in/out models
- can also be customised.

### BENEFITS FOR ALL

---

- Hundreds of \$ £ € saved through avoidance
- ATM is always protected, even when dispensing cash
- Flexible alarm options triggered instantaneously
- Installation requires no drills or sophisticated tools
- Protection begins within the hour
- No additional costs for consumables replacement
- No impact to replenishment personnel

For more information, visit [infomatservices.com](http://infomatservices.com), or write to us [info@infomatservices.com](mailto:info@infomatservices.com).

**InfoMAT**  
SERVICES